



Works with Google Cardboard

Guidelines and Best Practices

Introduction



“Works with Google Cardboard” Program has been designed to indicate to users that a given virtual reality viewer has been certified by the manufacturer to meet Google standards, and works well with thousands of applications made for the Google Cardboard ecosystem.

This document describes the best practices and lessons for manufacturing virtual reality viewers that are compatible with Works with Google Cardboard ecosystem. It includes guidelines for mechanical viewer components, instructions for generating software viewer profiles to ensure that all apps work well on your viewer, common pitfalls and things to avoid, and so on.

This document is accompanied by a set of specifications for manufacturing the new Google Cardboard (I/O 2015 edition). These specifications can be found in the manufacturing template collection ([wwgc_manufacturers_kit.zip](#)).

If you have any questions or comments about the Works with Google Cardboard program, contact us at wwgc@google.com.

Viewer guidelines

The following sections describe the guidelines for individual components of a typical “Works with Google Cardboard” viewer.

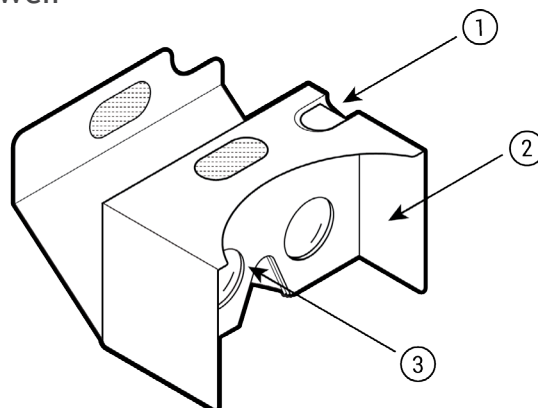

Figure 1. Typical components of a WWGC viewer: (1) - input, (2) - enclosure, (3) - lenses.



Input

- Your viewer should contain exactly one input. If your viewer has affordances for a direct screen touch, ensure that there is at most one dedicated area for touching the screen.
- Your viewer can use different types of inputs, from a simple smartphone screen touch, conductive and capacitive inputs, to Bluetooth-based buttons, and so on.
- If you're using a conductive input which passes user's body charge onto the smartphone screen, ensure that the input is not touching the screen in a "non-pressed" state.

Viewer enclosure

- You can use various materials for the viewer enclosure: cardboard, plastic, foam, aluminum and so on.
- An enclosure which fully blocks ambient/stray light is not mandatory. Lightweight forms of VR viewers with partial enclosures which do not necessarily block all ambient light may still work with Google Cardboard software ecosystem.
- If you're using cardboard for the enclosure, use the corrugated E-flute cardboard sheets. Flute thickness should not be less than 0.06" (1.5mm), otherwise the viewer itself will become unstable. This typically manifests in bending when opening/closing the top flap or side flaps.
- Similarly if you're using cardboard for the lens plate, apply food grade varnish or stickers to the cardboard to minimize unattractive staining on it, since it will be in frequent contact with skin.

Lenses

- If your viewer is using custom lenses, it may still be fully compatible with the Google Cardboard ecosystem. Just make sure to create a viewer profile to correct for lens barrel or pincushion distortion using the [Viewer Profile Generator](#) as described in "Viewer profile" section below.
- If you're designing custom lenses from scratch, aim for wide eyebox and avoid a mechanical inter-lens/IPD adjustment.
- If you're facing a trade-off between the FOV and the eyebox size, err on the side on the more forgiving eyebox.



- Google Cardboard (I/O 2015 edition) uses 34 mm diameter aspherical singlet lenses. You can find the exact specification and technical drawings of these lenses in [wwgc_manufacturers_kit.zip](#) template collection.

Parts to avoid

Do not include a headstrap with your viewer. When the user holds the Cardboard with their hands against the face, their head rotation speed is limited by the torso rotational speed (which is much slower than the neck rotational speed). This reduces the chance of “VR sickness” caused by rendering/IMU latency and increases the immersiveness in VR.

Magnet Input: We no longer recommend magnet-based inputs as they tend to work less reliably than conductive or capacitive inputs due to magnetometer variance within smartphones. Magnet-based viewers will no longer be certified or featured, and support within future versions of Cardboard apps will be limited.

Miscellaneous parts (hook and loop fastener, stickers, rubber band)

- If your viewer is using strips of adhesive-backed hook and loop fastener for flaps, make sure the adhesive is sufficiently strong not to loosen from the viewer over time, as the strips will be getting a lot of use.
- Ensure that the phone cannot easily slide out from the viewer. For example, you can use the rubber band or rubber dots to increase the friction between the phone and the viewer.
- If your viewer is made out of cardboard and has print assembly instructions on both sides, avoid designs that require perfect alignment on both sides. Also leave sufficient margins (1/4" - 1/8") between the print patterns and the die-cut lines.



Viewer profile

To ensure that all apps in the Google Cardboard app ecosystem work great on your viewer, create a QR viewer profile for your device using the [Viewer Profile Generator](#).

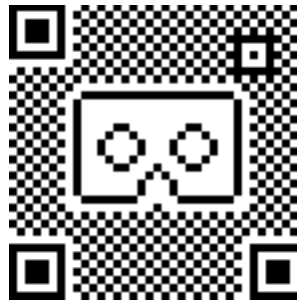

Figure 2. Typical output of this tool

Users will be prompted to scan this profile upon installing Google Cardboard apps for Android and iOS, so make sure that this QR profile is clearly placed. The recommended place for the profile is on the viewer itself, but you should also include it on the viewer's packaging, and/or on its website. You can find the detailed guidelines for sizing, spacing and other details of the generated QR profile in the [Viewer Profile and Badge Guidelines](#).

Usage Guidelines for WWGC Devices

Audiences

- Refrain from promoting and recommending Cardboard-like viewers to kids without conducting additional testing.
- If you include magnets, retain the messaging that the viewer contains magnets that may affect pacemakers.
- If your viewer is made out of cardboard, make sure that your audiences understand the limitations of the material: not water-resistant, potentially combustible (especially if lenses are facing a strong light source), limited life span.

Brand Use

Naming

- Do not use "Google Cardboard" or any similar name for your products, your domain name, your website, social media handles, or business, that makes your product look like an official Google product.



- Do not file trademark applications or otherwise claim trademark rights in any marks that are confusingly similar to Google's trademarks, including GOOGLE and GOOGLE CARDBOARD.
- Do not use any Google or Google Cardboard graphical assets (logos, product icons, etc) on your website, your physical products or in packaging without express, written authorization from Google.

Referring to Google Cardboard

- You are allowed to use any of the following approved text on your website or printed materials to refer to Google Cardboard:
 - This [XYZ VR headset] was inspired by Google Cardboard.
 - Inspired by Google Cardboard
- If you use any of the above approved text to refer to Google or Google Cardboard, you must include an attribution statement on your website that states "Google Cardboard is a trademark of Google Inc."

Other communications, media, and press

Do not overstate your relationship with Google: do not state or imply that you are an exclusive partner with Google. Do not suggest or imply that you have an exclusive or privileged arrangement with Google that differs from any other manufacturer.

Do not speak on behalf of Google, its representatives or products. You are welcome to conduct your own interviews and provide statements about your organization's specific product. However, please do not speak on behalf of Google or speculate about any Google initiatives. We're happy to take any questions from the press that are about Google as a company, Google's strategy, or the ins and outs of a Google product. Simply direct inquiries to press@google.com.

Applying to WWGC Program

1. Fill out the form at g.co/joinwwgc.
2. Send two (2) representative samples of each candidate viewer stock keeping unit (SKU) so that Google may evaluate them.

The samples should be sent to:



WWGC Program
1600 Amphitheatre Parkway
Mountain View, CA 94043

You are responsible for all costs associated with delivering the samples to Google. Google may keep the devices and is not required to return them to you.

Disclaimer

Google provides these guidelines in an effort to help manufacturers provide a quality VR user experience. Google, however, does not make any warrants or representations, does not accept any liability, and will not indemnify any manufacturers for these designs or for third-party viewers generally.

Change Log

Version	Date	Change Description
2.1	02/20/2016	Updated WWGC program criteria: products with magnet-based inputs will no longer be approved for certification.
2.0	09/1/2015	Updated to incorporate the new Google Cardboard (I/O 2015 edition) specifications.
1.2	04/16/2015	Added information about the "Works with Google Cardboard" Program.
1.0	12/10/2014	Initial manufacturing guidelines for Google Cardboard v1.1